

**TIMES** MICROWAVE SYSTEMS

## TC-400-TF-RP (stock code: 3190-1063) Type TNC-Female Plug Reverse Polarity (male pin)

Solder-on center contact  
Crimp-on (.429" hex.) outer contact

### INSTALLATION INSTRUCTIONS

(Cable Types: LMR-400; 400 DB; 400 FR; 400 Ultraflex; 400 LLPL )

SLIGHT CHAMFER

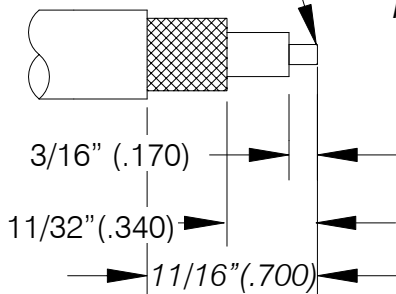

STEP 1

- (A) Trim cable to dimensions shown using a razor knife or Times ST-400EZ strip tool.  
(B) Remove any residual plastic from center conductor.  
(C) Deburr center conductor using a fine file or Times DBT-01 tool.  
(D) Avoid nicking aluminum tape or center conductor.

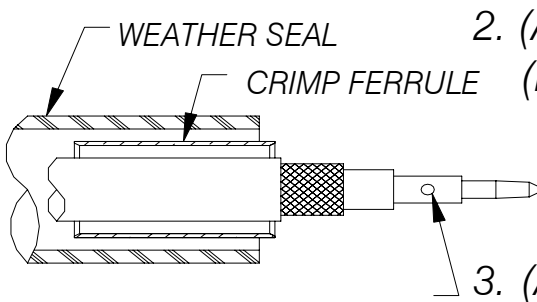

STEP 2 SOLDER

- (A) Slide weather seal and crimp ferrule over cable.  
(B) Seat center contact firmly against cable dielectric and solder cable to conductor. Use minimal heat to minimize melting of foam dielectric.

TRIM BRAID

STEP 3

- (A) Flare braids and insert cable into connector body until dielectric is seated with all braid wires on outside and aluminum tape inside of body.  
(B) Braid should assemble flush to within 1/16" (.06) of connector shoulder. Trim braid as necessary.  
(C) Slide crimp ferrule over braid and crimp as close to body as possible using hex.die indicated in a Times HX-4 crimp tool or equivalent. Do not crimp rear of crimp ferrule.  
(D) Heat shrink weather seal over rear of connector body and down on to cable jacket using hot air gun.

REV-C