

TIMES MICROWAVE SYSTEMS

EZ-240-FMH-75 (stock code: 3190-1613) Type F PLUG

Non-solder center contact
Crimp-on (.255" hex. die) outer contact

INSTALLATION INSTRUCTIONS

(Cable Types: LMR-240-75)

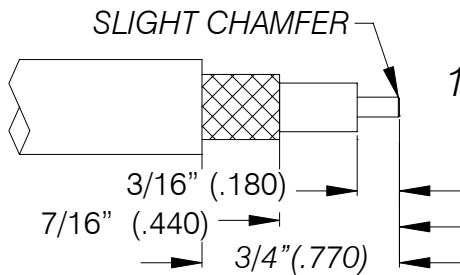

STEP 1

1. (A) Trim cable to dimensions shown.
(B) Remove any residual plastic from center conductor.
(C) Deburr center conductor using a fine file or Times DBT-01 tool.
(D) Avoid nicking aluminum tape.

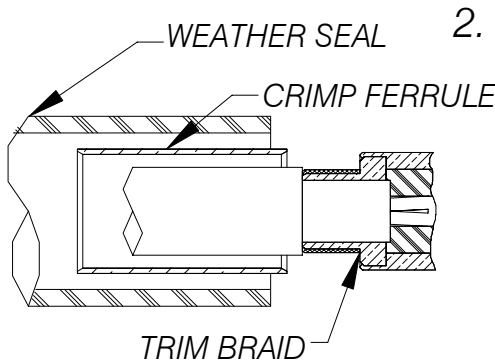

STEP 2

2. (A) Slide weather seal and crimp ferrule over cable.
(B) Flare braid and insert cable into connector body until dielectric is seated with all braid wires on outside of connector body and aluminum tape inside connector body.
(C) Braid should assemble flush to within 1/16" (.06) of connector shoulder. Trim excess if necessary.

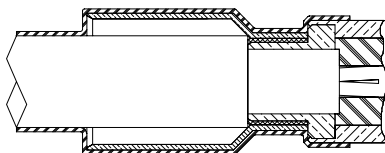

STEP 3

3. (A) Slide crimp ferrule over braid and crimp as close to body as possible using hex. die indicated in a Times HX-4 crimp tool or equivalent. Do not crimp rear of crimp ferrule.
(B) Heat shrink weather seal over rear of connector body and down on to cable jacket using hot air gun.