

NOTICE OF PROPRIETARY RIGHTS THIS DOCUMENT CONTAINS CONFIDENTIAL DATA, INCLUDING TRADE SECRETS, PROPRIETARY TO TIMES MICROWAVE SYSTEMS. DISCLOSURE OF THIS DATA IS EXPRESSLY CONDITIONED UPON YOUR ASSENT THAT ITS USE IS LIMITED TO USE WITHIN YOUR COMPANY ONLY. ANY OTHER USE IS STRICTLY PROHIBITED WITHOUT THE PRIOR WRITTEN CONSENT OF TIMES MICROWAVE SYSTEMS.

SYM	REVISION DESCRIPTION	DFTM	DATE	APPD	APPD
A	RELEASED FOR PRODUCTION	Patrick	2019/03/30	Joslen	2019/03/30

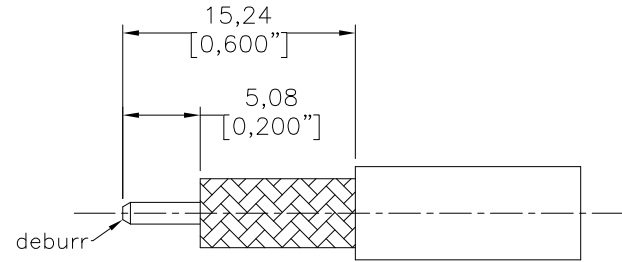
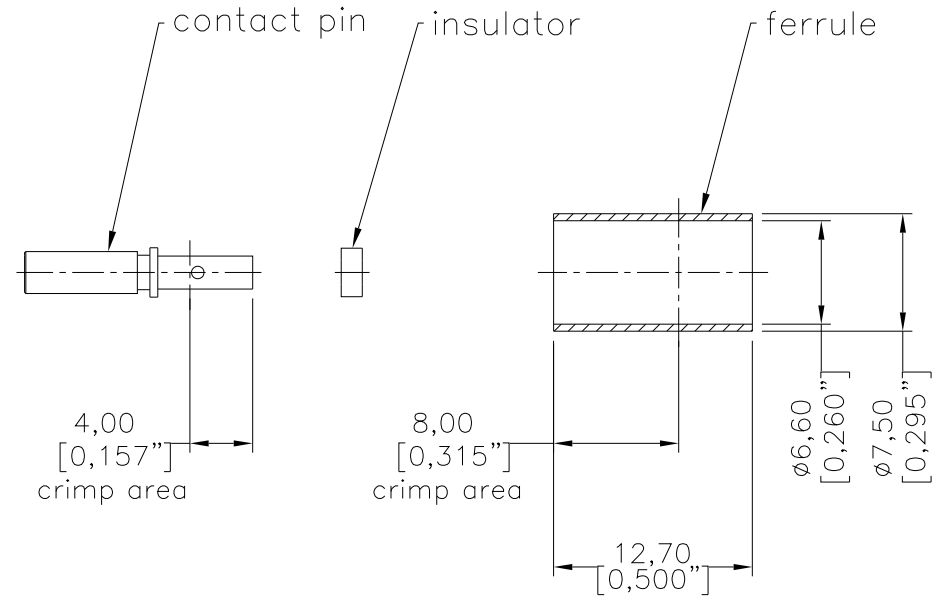
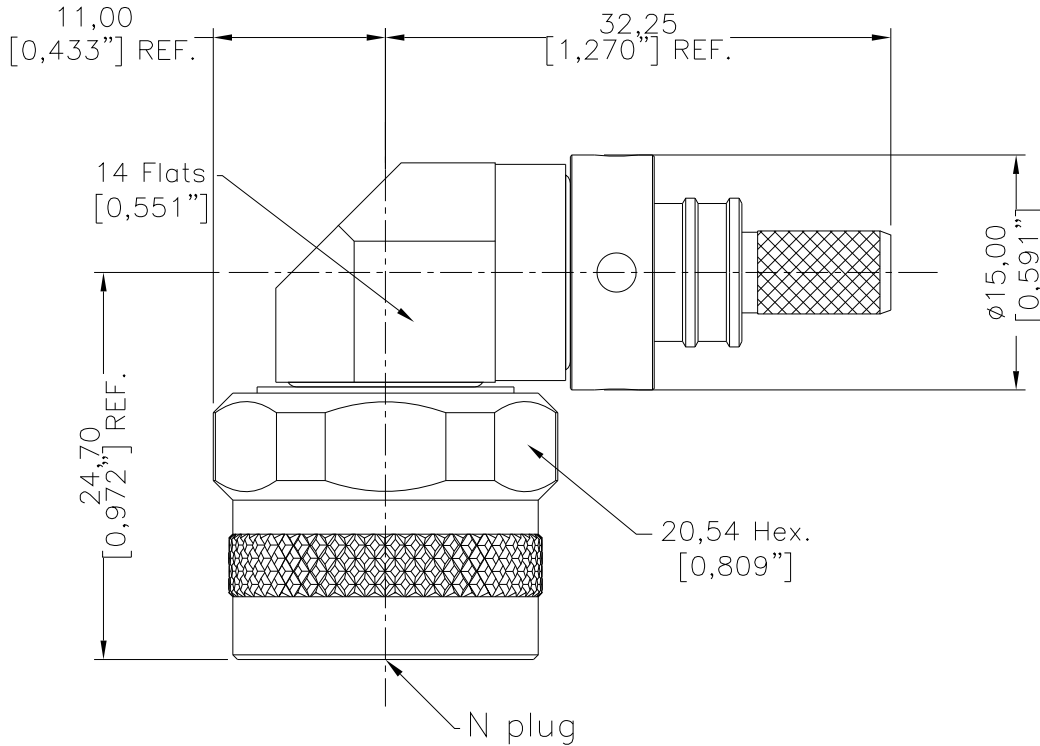

RECOMMENDED CABLE STRIPPING DIM'S
Connector Adds: 17.7 mm

I. MATERIALS & FINISHES

Components	Materials	Finishes	Thk. (μ")
Body	Brass	Sn-Ni	100
Contact Pin	Beryllium Copper	Gold	50
Insulator	PTFE	--	--
Coupling Nut	Brass	Sn-Ni	100
Ferrule	Brass	Sn-Ni	100
Gasket	Silicone Rubber	--	--

II. ELECTRICAL PROPERTIES

Impedance (Ω):	50
Frequency Range (GHz):	DC-6
Dielectric Withstanding Voltage (V):	1500
Insulation Resistance (MΩ):	≥5000
VSWR: for solder center contact	≤1.35
for crimp center contact	≤1.40
Insertion Loss(dB, f in GHz):	-0.1x√f

III. ENVIRONMENT PROPERTIES

Temperature Range:	-65°C~+165°C
Thermal Shock:	MIL-STD 202G, Meth.107, Cond. B
Vibration:	MIL-STD 202G, Meth.204, Cond. B
Shock:	MIL-STD 202G, Meth.213, Cond. I
Climatic Class:	IEC 60068 55/155/21
RoHS:	Compliant

IV. MECHANICAL PROPERTIES

Center Contact:	Solder/Crimp
Outer Contact:	Crimp
Coupling Nut Torque (in.lbs):	6-10
Cbl-Connector Retention Force (lbs):	60
Durability (Cycles):	500

V. TOOLING

Stripping Tool:	N/A
Crimping Size	
Center Contact:	.068" HEX.
Outer Contact:	.255" HEX.
Heat Shrink Tube:	1/2"x1.5" (3:1) 1 pcs

Interface Compatible with Standard:
IEC 61169-16
MIL-STD-348

MATL:	UNLESS OTHERWISE SPECIFIED	DFTM. Patrick	TIMES MICROWAVE SYSTEMS An Amphenol Company			
	ALL DIMENSIONS ARE IN mm MACHINED SURFACES FINISH 1.6 RMS MAX. REMOVE ALL BURRS 0.15X45° MAX. BREAK MACHINE CORNERS 0.15X45° D MAX. FILLET R. TOLERANCES ON DECIMALS X ±0.3 XX ±0.15 ANGLES ±2° FRACTIONS ± N/A	DATE 2019/03/30	TC-3115-NMH-RA-X Type N Male (Plug) Right Angle Solder/Crimp Pin No Braid Trim Connector for TCA311501 Cable			
		CHKD Monica				
USED ON: O		DATE 2019/03/30				
		APPD Joslen				
SCALE: N/A DWG SIZE: A3	DO NOT SCALE DRAWING	CODE ID/FNT 68999	DATE 2019/03/30	SHT 1/1	3190-8066	REV A