

NOTICE OF PROPRIETARY RIGHTS: THIS DOCUMENT CONTAINS CONFIDENTIAL DATA, INCLUDING TRADE SECRETS, PROPRIETARY TO TIMES MICROWAVE SYSTEMS. DISCLOSURE OF THIS DATA IS EXPRESSLY CONDITIONED UPON YOUR ASSENT THAT ITS USE IS LIMITED TO USE WITHIN YOUR COMPANY ONLY. ANY OTHER USE IS STRICTLY PROHIBITED WITHOUT THE PRIOR WRITTEN CONSENT OF TIMES MICROWAVE SYSTEMS.

VER	Description	ECN	Name	Date
A	Initial Released	N/A	Patrick	2018/10/20

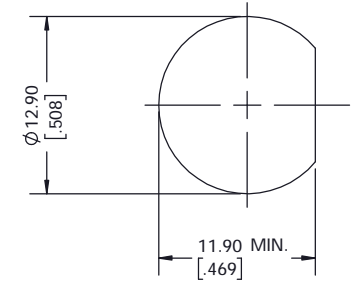
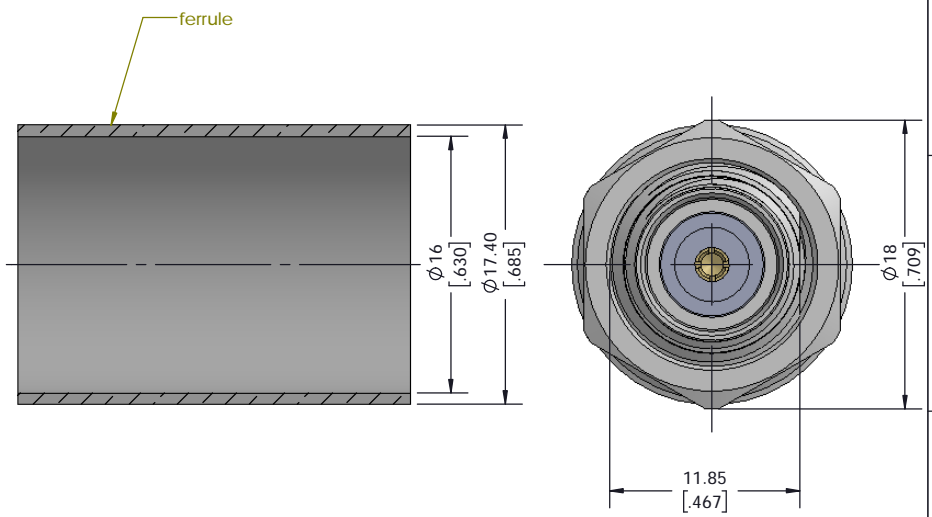
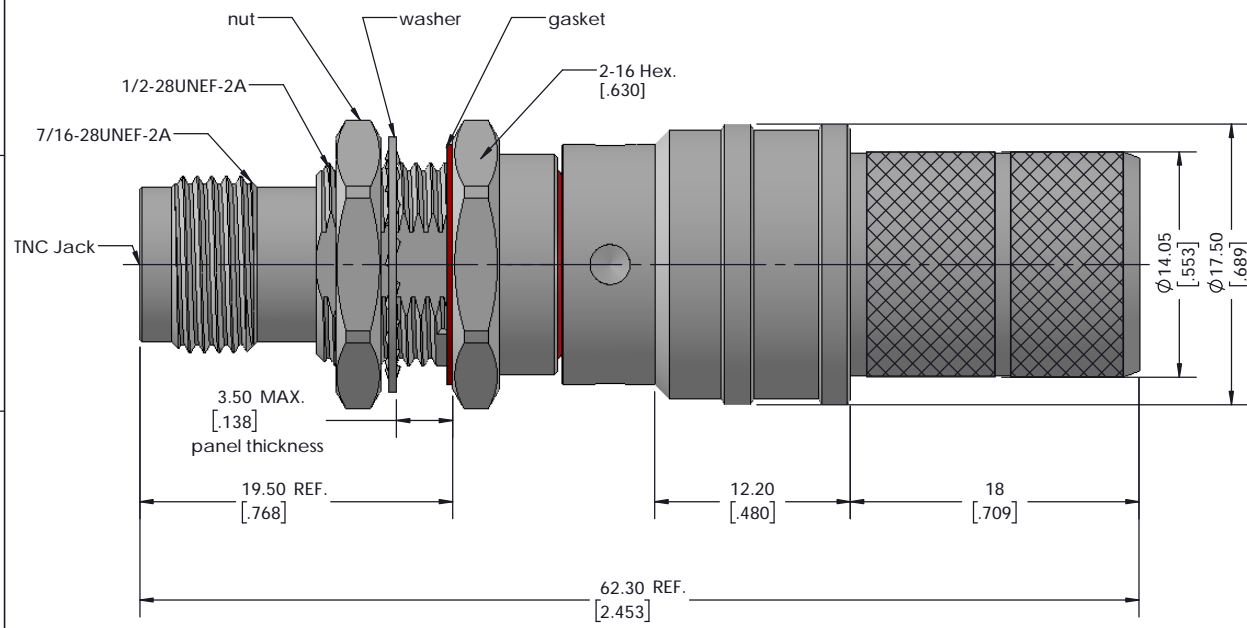

I. MATERIALS & FINISHES			
Component	Material	Finishes	Thk. (u")
Body	Brass	Sn-Ni	100
Contact Pin	Beryllium Copper	Gold	50
Insulator	PTFE	--	--
Nut / Washer	Brass	Sn-Ni	100
Ferrule	Copper	Sn-Ni	100
Gasket	Silicone Rubber	--	--

II. ELECTRICAL PROPERTIES	
Impedance (Ω):	50
Frequency Range (GHz):	DC~8 GHz
Dielectric Withstanding Voltage (V r.m.s.):	1500
Insulation Resistance (M Ω):	≥ 5000
VSWR:	≤ 1.30 (DC~6 GHz)
	≤ 1.35 (6~8 GHz)
Insertion Loss (dB, f / GHz):	-0.1 x sqrt (f)

III. ENVIRONMENT PROPERTIES	
Temperature Range:	-40°C~+125°C
Thermal Shock:	MIL-STD-202, Meth. 107, Cond. B
Vibration:	MIL-STD-202, Meth. 204, Cond. B
Shock:	MIL-STD-202, Meth. 213, Cond. G
Climatic Class:	IEC 60068 55/155/21
RoHS:	Compliant

IV. MECHANICAL PROPERTIES	
Center Conductor:	Spring Finger
Outer Conductor:	Crimp
Coupling Nut Torque (in-lbs):	4.1~6.1
Cable-Connector Retention Force (lbs):	200
Durability (Cycles):	500

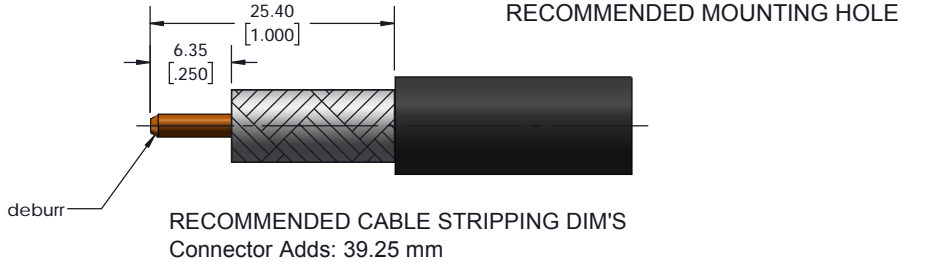

- V. Tooling & Accessories**
- Stripping Tool: 3192-052/CST-1600
 - Crimping Tool: 3192-170/CT-600
 - Heat Shrink Tube: 1"x2" (3:1) 1 pcs

UNLESS OTHERWISE SPECIFIED		DFTM Patrick	TIMES MICROWAVE SYSTEMS An Amphenol Company EZ-600-TF-BH-X TNC Female (Jack) Straight Non-Solder Pin No Braid Trim Bulkhead Connector for LMR-600 Cable
ALL DIMENSIONS ARE IN mm MACHINED SURFACES FINISH 1.6 RMS MAX. REMOVE ALL BURRS 0.15X45° MAX. BREAK MACHINE CORNERS 0.15X45° D MAX. FILLET R. TOLERANCES ON DECIMALS .X ± 0.1 .XX ± 0.15 ANGLES $\pm 2^\circ$ FRACTIONS $\pm N/A$		DATE 2018/10/20	
		CHKD Monica	
		DATE 2018/10/20	
		APPD Joslen	
Scale:	3:1	Size:	A3
CODE IDENT	68999	DATE	2018/10/20
SHT	1/1	3190-8035	REV A