

**NOTICE OF PROPRIETARY RIGHTS** THIS DOCUMENT CONTAINS CONFIDENTIAL TECHNICAL DATA, INCLUDING TRADE SECRETS, PROPRIETARY TO TIMES MICROWAVE SYSTEMS. DISCLOSURE OF THIS DATA IS EXPRESSLY CONDITIONED UPON YOUR ASSENT THAT ITS USE IS LIMITED TO USE WITHIN YOUR COMPANY ONLY. ANY OTHER USE IS STRICTLY PROHIBITED WITHOUT THE PRIOR WRITTEN CONSENT OF TIMES MICROWAVE SYSTEMS.

SYM	REVISION DESCRIPTION	DFTM	DATE	APPD	DATE
A	RELEASED FOR PRODUCTION	N. N. N.	9/5/13	J. D. B.	9/10/13
B	CHANGED PER CDC #41149	D. J. H.	11/13/14	J. D. B.	11/20/14

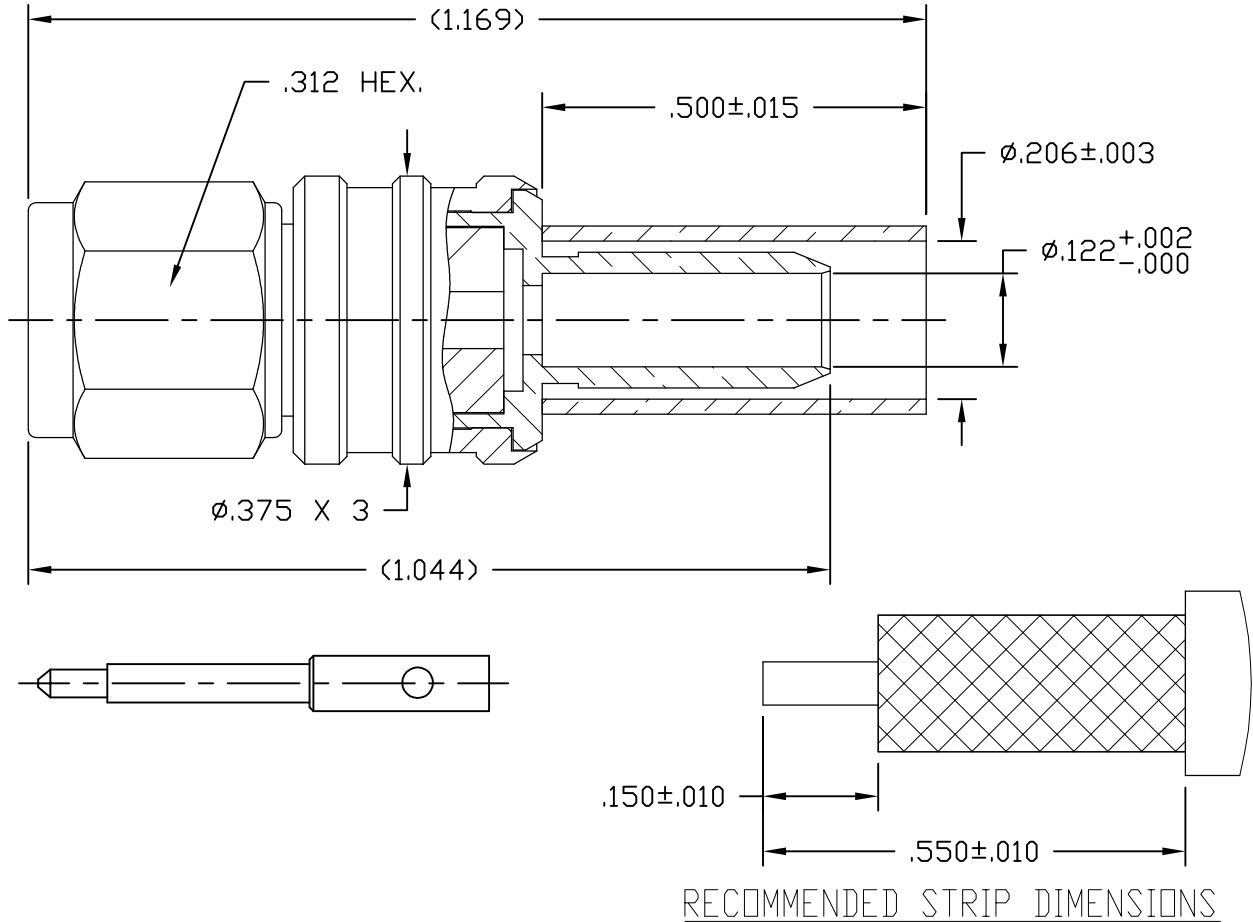

**NOTES:**

- INTERFACE IS DESIGNED IN ACCORDANCE WITH MIL-STD-348.
- MATERIAL: BODY & NUT – STAINLESS STEEL PER ASTM 582, S30300 ALLOY, COND. A.  
 INSULATOR – TEFLON PER ASTM D1710, TYPE 1, GRADE 1, CLASS A.  
 CONTACT & TAIL – BRASS PER ASTM B16, C36000 ALLOY, TEMPER H02.  
 GASKET – SILICONE RUBBER PER A-A-59588, 50-75 DUROMETER.  
 SHRINK SLEEVE – HEAT SHRINKABLE ATUM PER MIL-I-23053/4 (NOT SHOWN).  
 CRIMP SLEEVE – D.H.P. COPPER CDA ALLOY #122, TEMPER HARD.  
 LOCKING RING – BERYLLIUM COPPER PER ASTM B196, C17300 ALLOY, CONDITION HT.
- FINISHES: CONTACT – GOLD PLATE PER ASTM B488.  
 TAIL – NICKEL PLATE PER AMS-QQ-N-290.  
 CRIMP SLEEVE – SULFAMATE NICKEL PER MIL-P-27418.  
 ALL OTHER METAL PARTS – PASSIVATE PER SAE-AMS-2700.

MATL:	UNLESS OTHERWISE SPECIFIED		DFTM. N. N. N.	TIMES MICROWAVE SYSTEMS	
	ALL DIMENSIONS ARE IN INCHES MACHINED SURFACES FINISH N/A RMS MAX. REMOVE ALL BURRS .005 MAX. BREAK MACHINE CORNERS .005 MAX. FILLET R. TOLERANCES ON DECIMALS . XX ± .03 . XXX ± .005 ANGLES ± 1° FRACTIONS ± 1/32		DATE 9/5/13		
USED ON: B	DO NOT SCALE DRAWING		CHKD. J. D. B.	<b>TC-195-SM-SS-X</b> "SMA" MALE FOR LMR-195 CABLE (SOLDER/CRIMP)	
			DATE 9/10/13		
SCALE: N/A	DWG. SIZE A	CODE IDENT 68999	APPD. J. D. B.	DATE 9/10/13	SHEET 1 of 1
				SD3190-2878	REV B