

SYM	REVISION DESCRIPTION	DFTM	DATE	APPD	APPD
A	RELEASED FOR PRODUCTION	Joslen	2017.05.27	TZ	2017.05.27

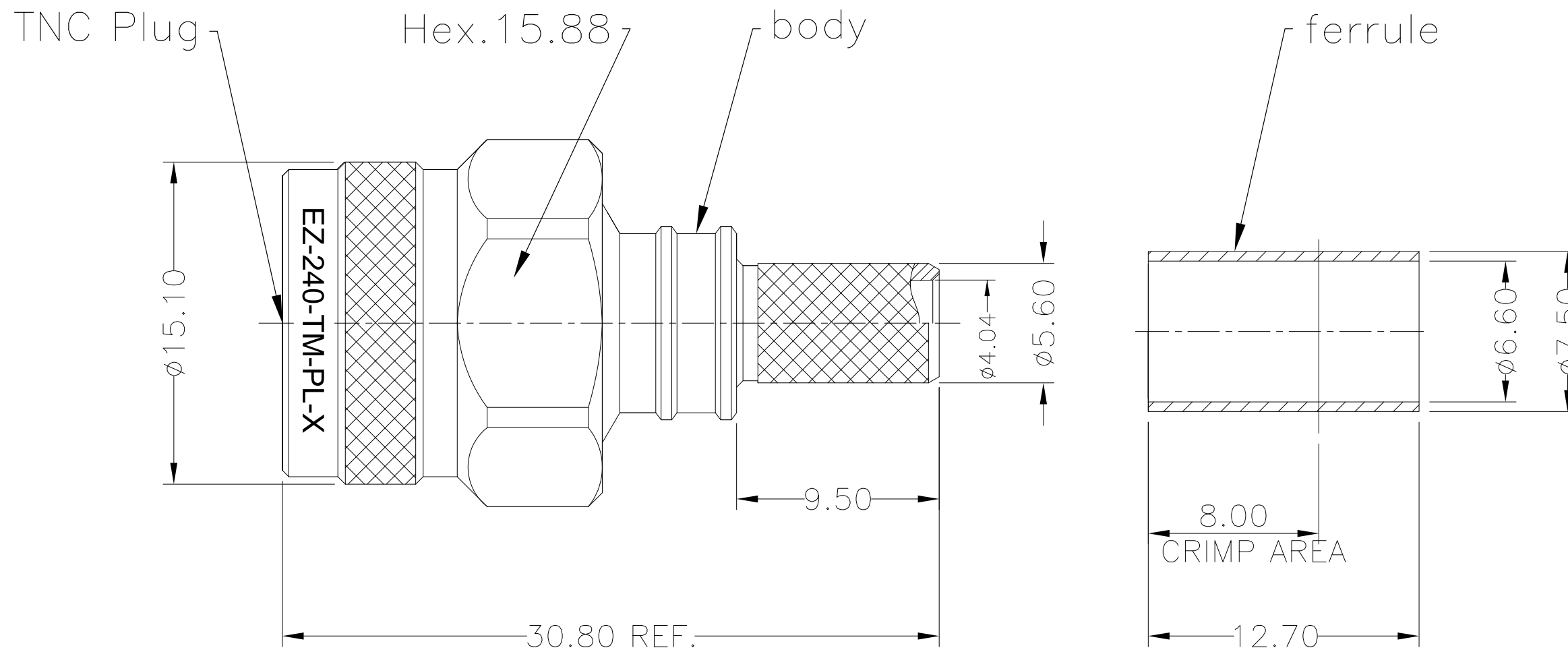

**I. MATERIALS & FINISHES**

Components	Materials	Finishes	Thk. (μ")
Body	Brass	Albaloy	80
Center Cont.	QBe2	Gold	50
Ferrule	Brass	Albaloy	80
Nut	Brass	Albaloy	80
Insulator	PTFE	--	--
Gasket	Silicone	--	--

**II. ELECTRICAL PROPERTIES**

Impedance (Ω):	50
Frequency Range (GHz):	DC to 6 GHz
Working Voltage (V):	2500
Insulation Resistance (MΩ):	≥10000
VSWR:	≤1.30
Insertion Loss(dB, f/GHz):	-0.1x √f

**III. ENVIRONMENT PROPERTIES**

Temperature Range:	-40°C~+125°C
Thermal Shock:	MIL-STD 202G, Meth.107, Cond.B
Vibration:	MIL-STD 202G, Meth.204, Cond.B
Shock:	MIL-STD 202G, Meth.213, Cond I
Climatic Class:	IEC 60068 55/155/56
(2002/95/EC)RoHS:	Compliant

**IV. MECHANICAL PROPERTIES**

Center Cont.:	Finger Contact
Outer Cont.:	Crimp
Coupling Nut Torque (N.m):	1.7
Cbl-Connector Retention Force (N):	250
Durability (cycles):	500

**V. TOOLING**

Stripping Tool: 3192-152  
Crimping Tool: 3190-667/CT-240/200/100

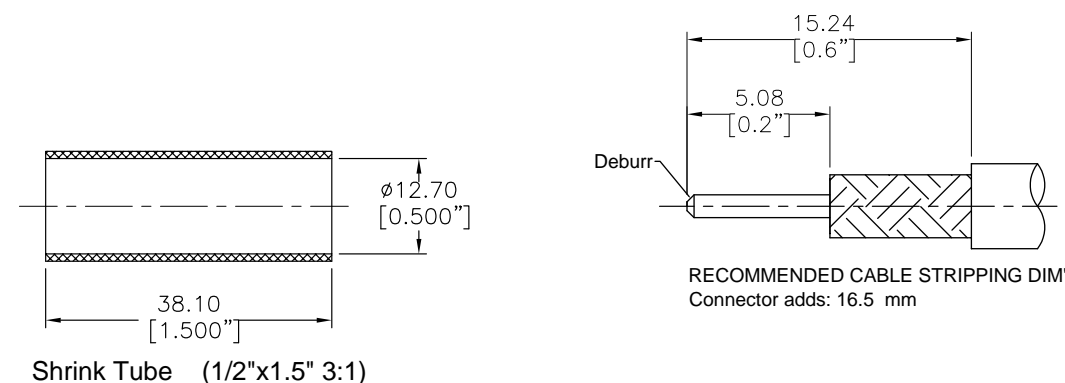

According to Standard: IEC 61169-17

UNLESS OTHERWISE SPECIFIED			DFTM.	TIMES MICROWAVE SYSTEMS An Amphenol Company		
ALL DIMENSIONS ARE IN mm MACHINED SURFACES FINISH 1.6 RMS MAX. REMOVE ALL BURRS 0.15X45° MAX. BREAK MACHINE CORNERS 0.15X45° D MAX. FILLET R. TOLERANCES ON DECIMALS .X ±0.3 .XX ±0.15 ANGLES ±2° FRACTIONS ± N/A			Joslen	<b>EZ-240-TM-PL-X</b> TNC Male (Plug) Straight Non- Solder Pin No Braid Trim Connector for LMR-240-LLPL Cable		
			DATE			2017.05.27
			CHKD			KG
			DATE			2017.05.27
DO NOT SCALE DRAWING			APPD	TZ	1 OF 1 <b>3190-6373</b>	
CODE IDENT	68999	DATE	2017.05.27	REV		A